

V-BOX ACTIVE

STEREO ACTIVE DIRECT BOX

INTRODUCTION

The V-BOX mark-II stereo active direct box is a high performance active direct box for live concert touring and professional recording studio applications, with the ability to handle extreme transients without distortion while delivering the natural sound of your instrument.



FEATURE

- Increased dynamic range and headroom
- Retains the natural sound of the instrument
- Powered by 48V phantom, no batteries required

OVERVIWE

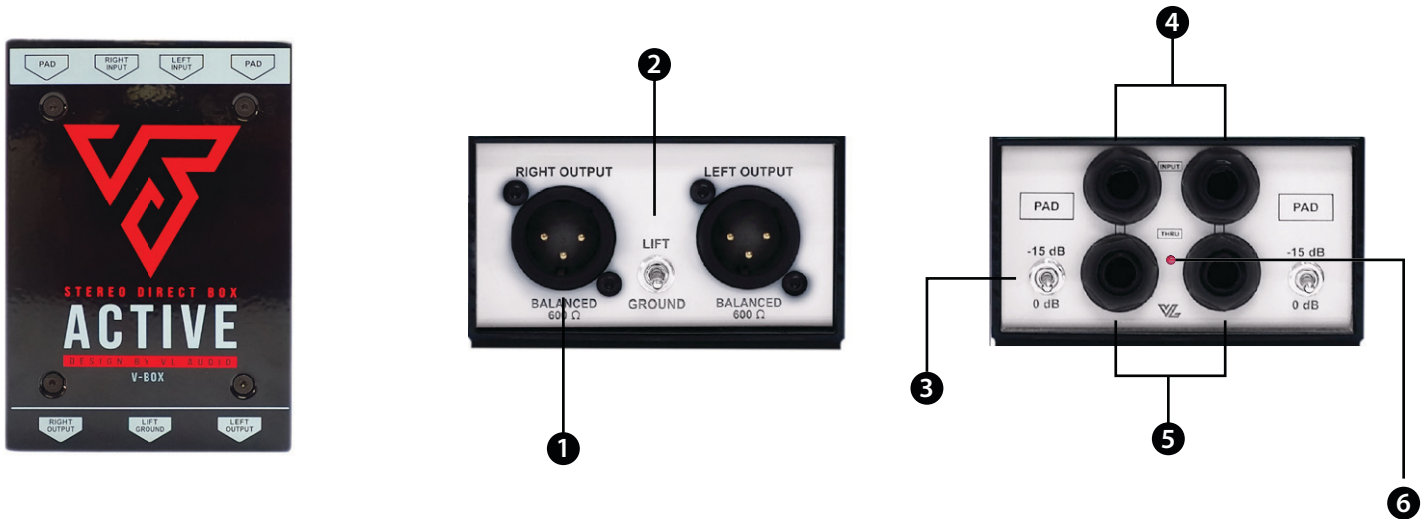

1. **Line-level outputs** Balanced input, male XLR connectors.
2. **Ground/Lift switch** Disconnects XLR pin-1 on both INPUT-1 and INPUT-2.
3. **Pad** Reduces the input sensitivity for active basses and high-output keyboards.
4. **1/4" Input** Instruments connection to the V-BOX mark-II stereo passive direct box.
5. **1/4" Thru** Instruments thru-put to an amplifier.
6. **Phantom power LED** Light to confirm phantom-power is present working.

BLOCK DIAGRAM

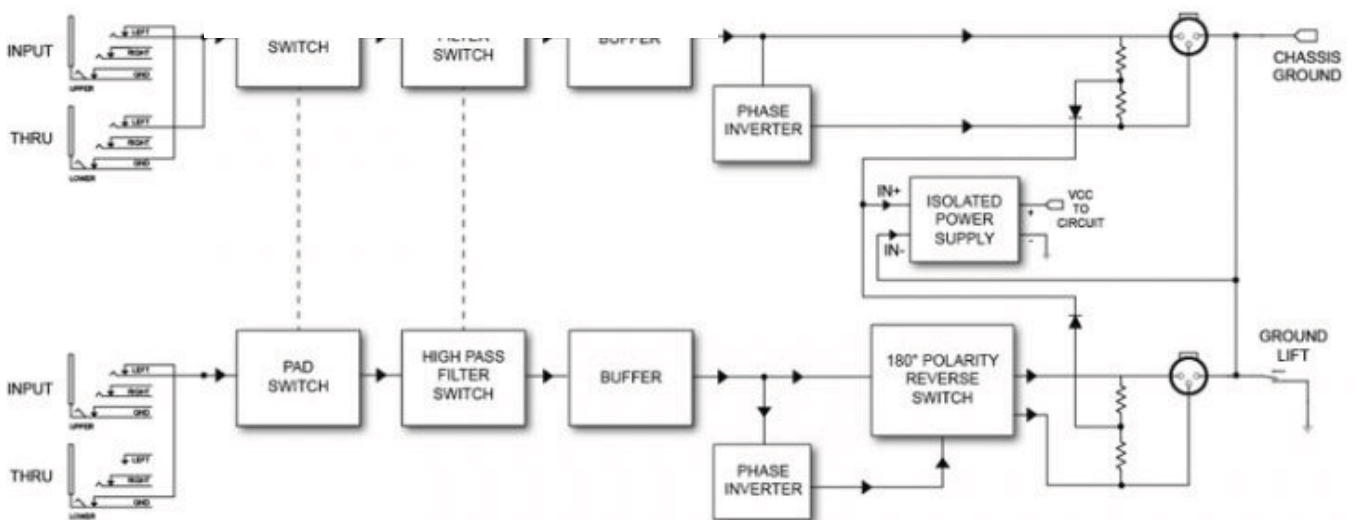

TECHNICAL SPECIFICATIONS

SPECIFICATIONS	Audio circuit type	Proprietary analog circuit with low-noise op-amp
	Number of channels	Stereo (dual mono)
	Frequency response	20Hz - 20kHz
	Dynamic range	135dB
	Total harmonic distortion	0.0020% @ 1k, +4dBu
	Phase Deviation	-10° @ 20Hz, 2° @ 100Hz
	Input Impedance	140kΩ, Unbalanced
	Output Impedance	600Ω, Balanced
	Maximum Input	+21 dBu @20Hz - 20kHz (with Pad)

FEATURES	Ground lift	Yes
	Phantom power LED	Yes
	Input Connectors	1/4"
	Output Connectors	XLR male output

General	Conditions	For use in dry locations only
	Warranty	Life time

Size	Height	4.8 cm.
	Width	8.3 cm.
	Depth	12 cm.
	Weight	0.37 cm.

Shipping informations	Package Height	4.8 cm.
	Package Width	9.8 cm.
	Package Depth	13.5 cm.
	Package Weight	0.47 cm.

APPLICATIONS



**MULTI EFFECT
(BOSS GT-1)**

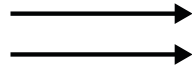

V-BOX STEREO ACTIVE

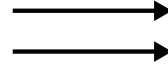

**DIGITAL MIXER
(Allen&Heath QU16)**



Keyboard (Nord stage 3)

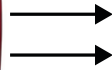

V-BOX STEREO ACTIVE

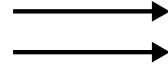

**DIGITAL MIXER
(Allen&Heath QU16)**



**Electric Drum
(Roland VAD-306)**

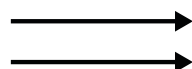

V-BOX STEREO ACTIVE

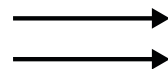

**DIGITAL MIXER
(Allen&Heath QU16)**

Graphs Frequency Response

Stereo Direct Box Passive Total Harmonic Distortion vs Frequency

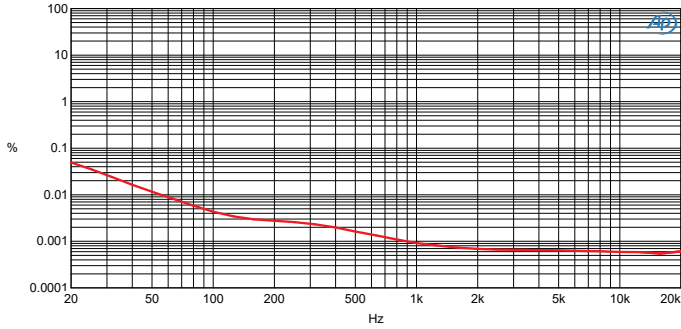

Stereo Direct Box Passive Noise Spectrum

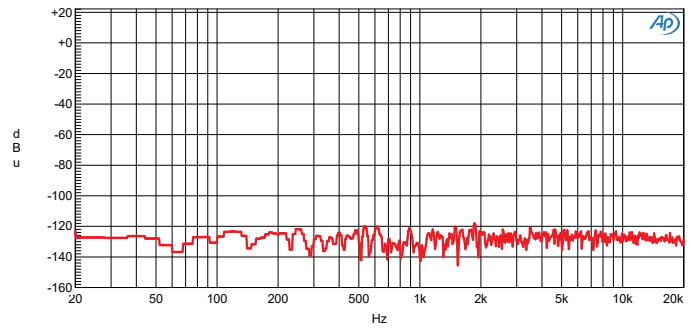

Stereo Direct Box Active Phase Shift

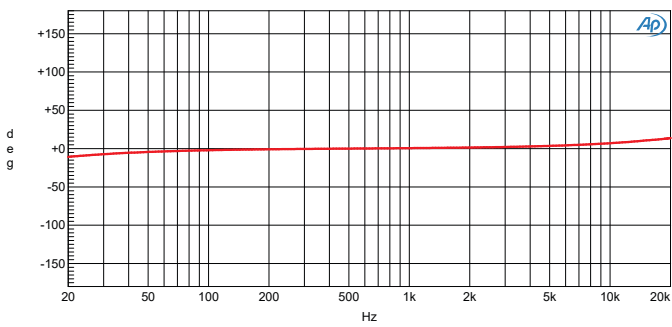

Stereo Direct Box Active Frequency Response

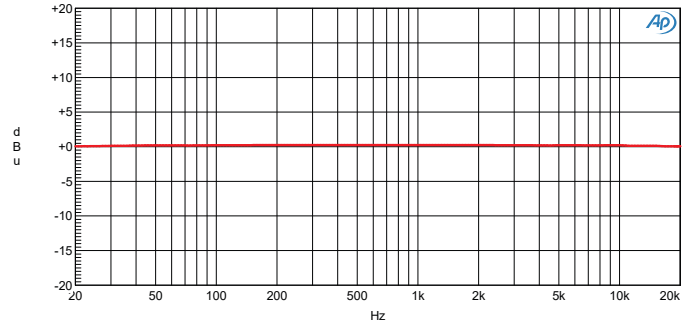

Stereo Direct Box Passive Fast Fourier Transform

